



News for 09/24/08

Update on the E-Jet

---

Hi Again!

Our patent-pending dAM E-Jet is moving right along. If you recall, it replaces both the float bowl and the main jet and is controlled by the ECU. There is no float and needle to be affected by acceleration forces. Our test stand is just about complete; the fuel system is in place; and the ECU is already here. Arrival of the prototypes is imminent. Here's another look at the CAD drawings. Stay tuned for photos of a prototype!

John

PS: Reward of \$250.00 if anybody has a copy of my 1992 Superflow Presentation on VHS, please contact me.

---

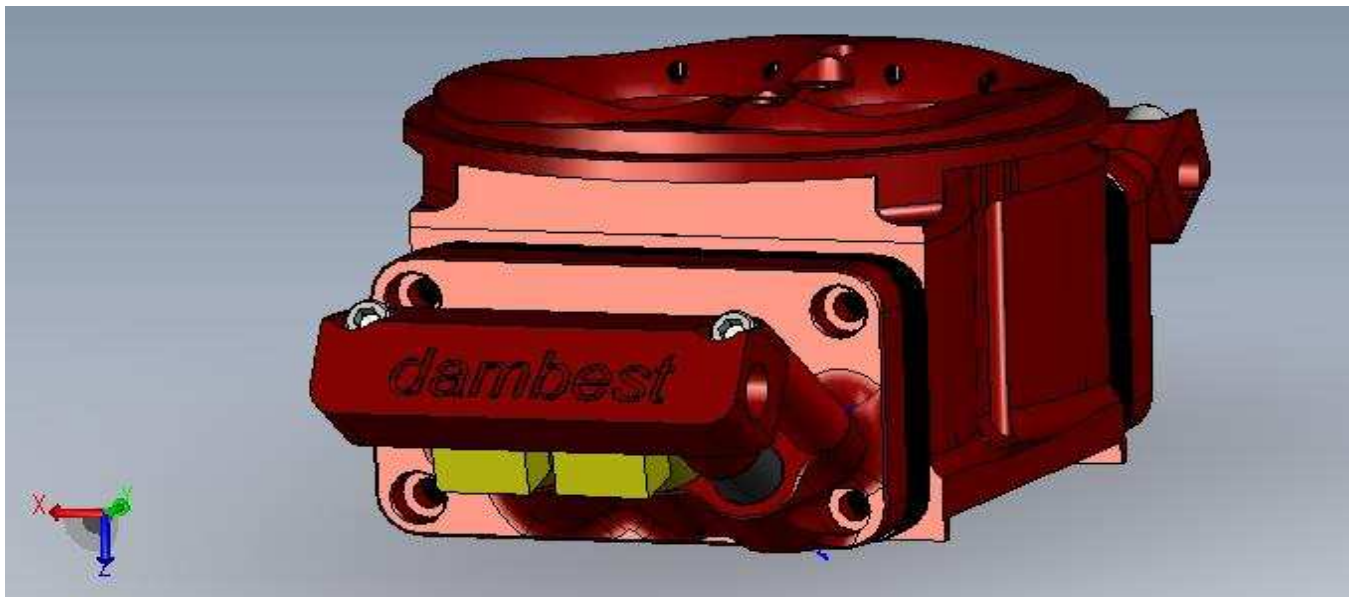

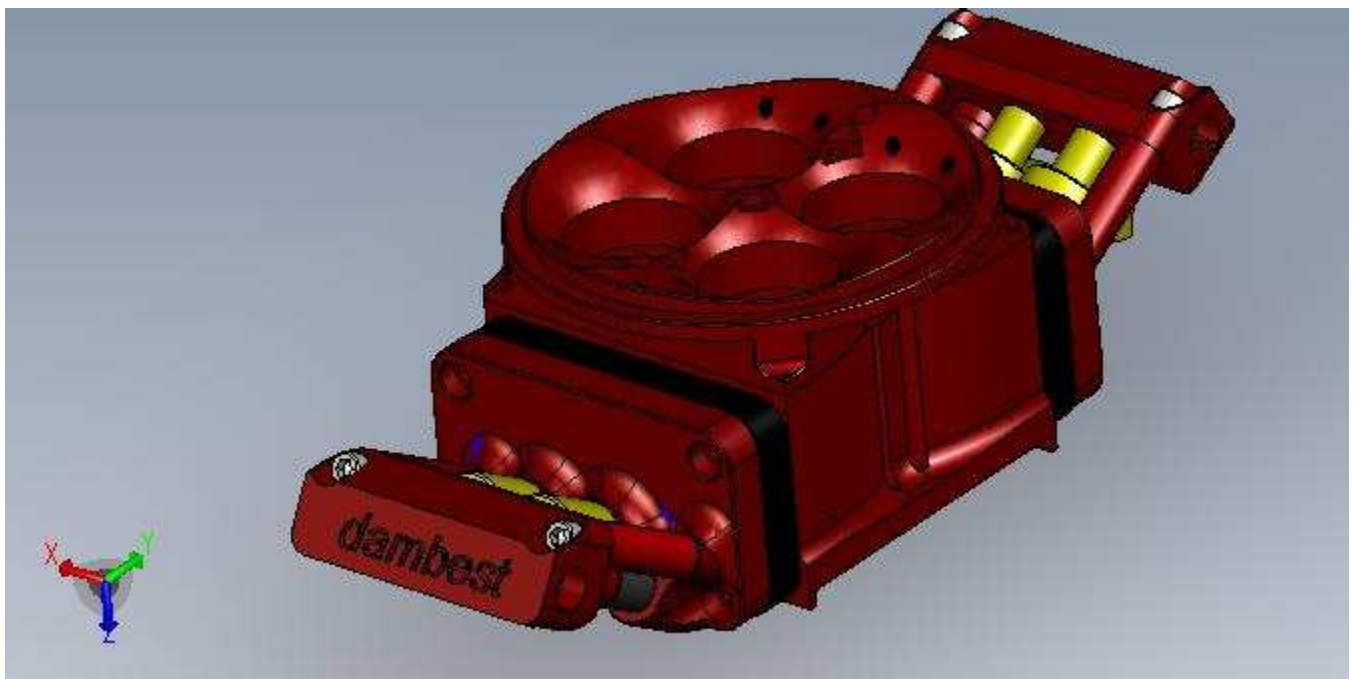
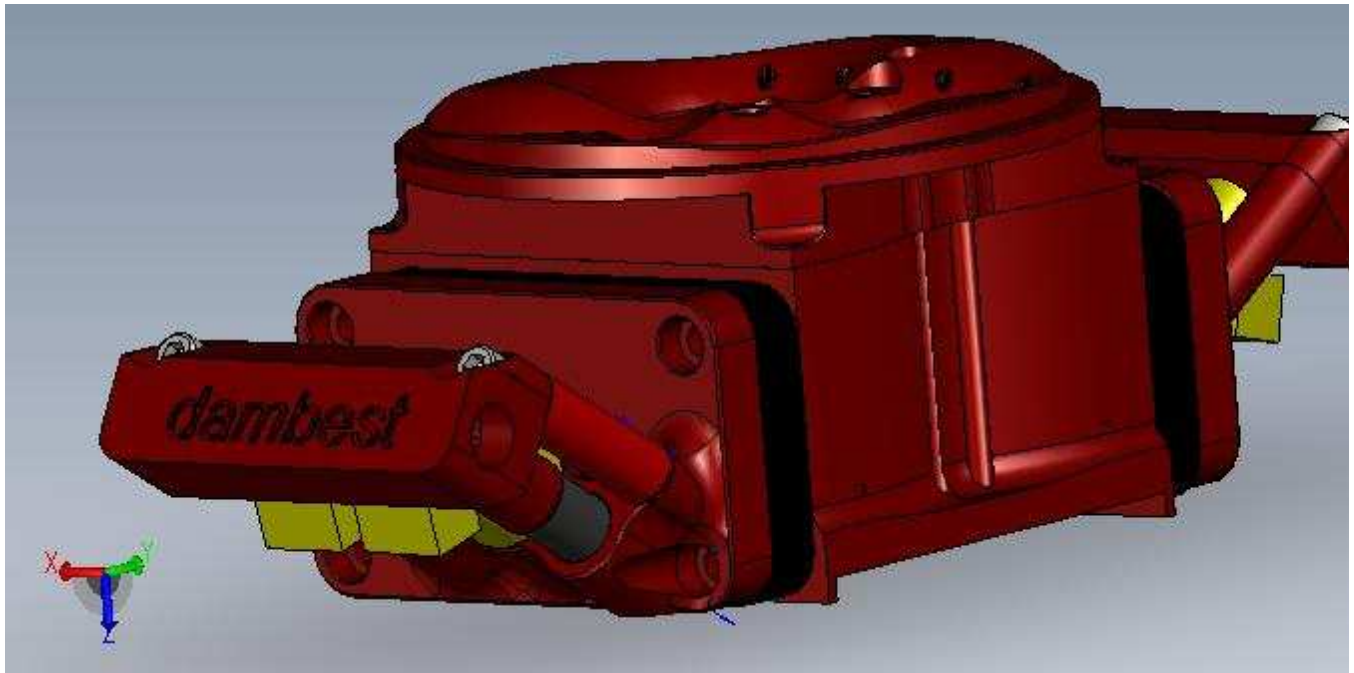

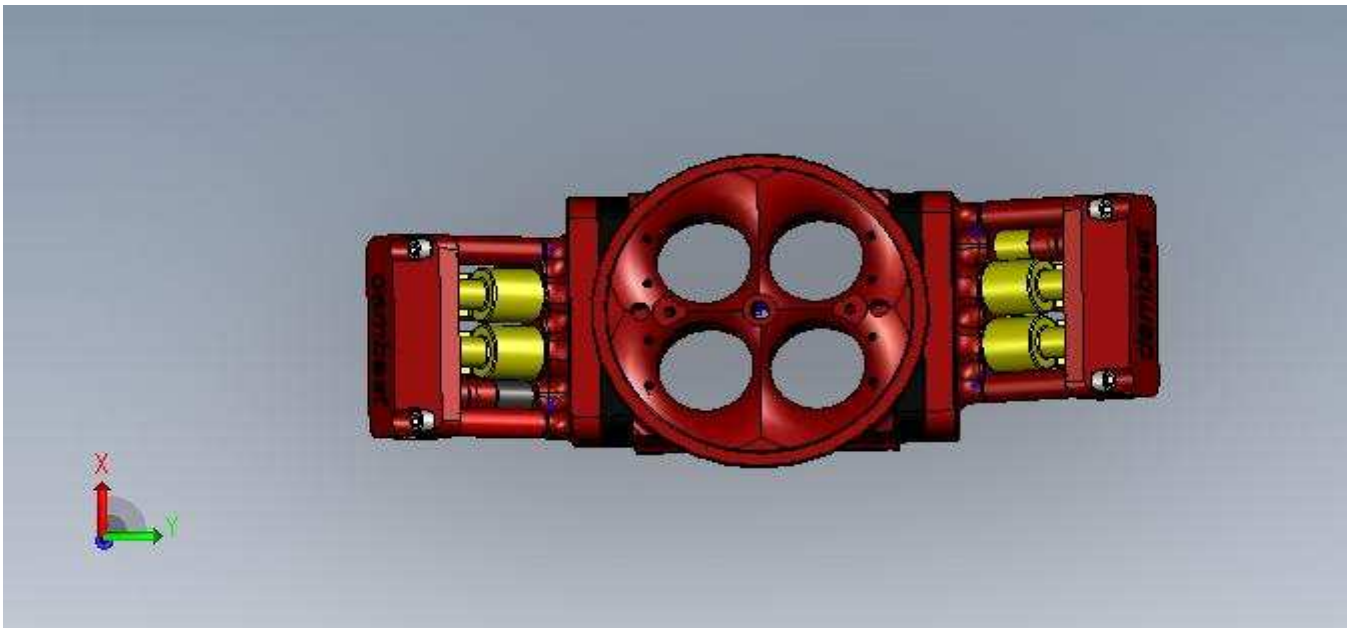
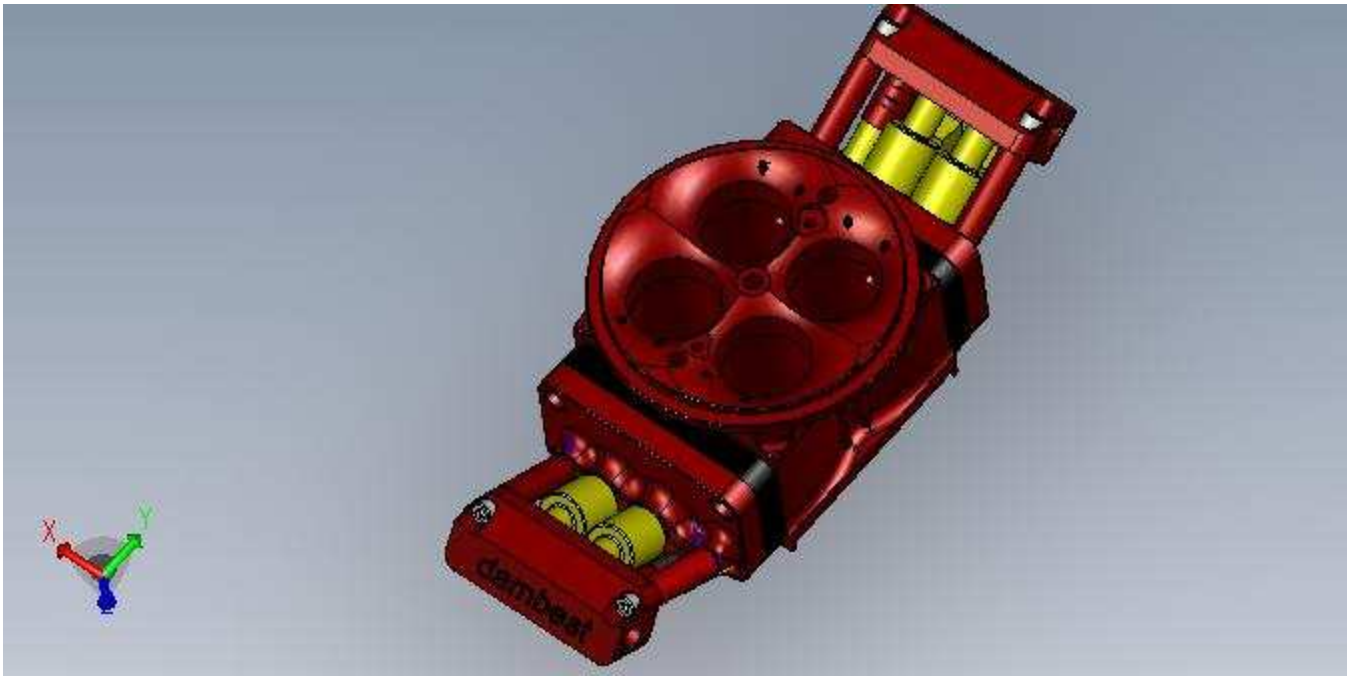

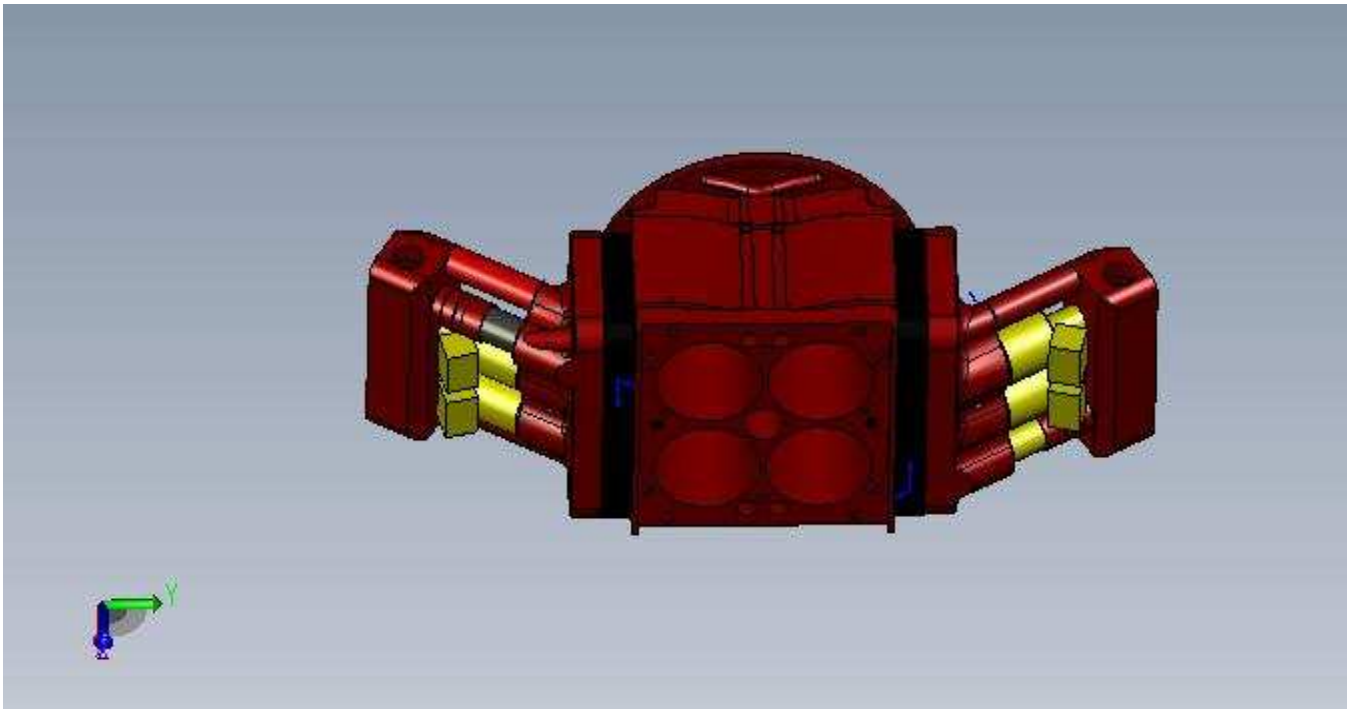

Visit [dambest.com](http://dambest.com).

---

If you do not wish to receive this News Letter, just reply with REMOVE.  
Please quote or forward the complete News Letter to help us remove the correct  
address.